

ALLEGANY COUNTY DEPARTMENT OF
PUBLIC WORKS

7 Court Street, Room 210
Belmont, New York 14813
Telephone: 585-268-9230 Fax: 585-268-9648

NOTICE TO BIDDERS

The Allegany County Department of Public Works will receive sealed bids until 10:00 a.m. March 16, 2010. At that time, bids will be opened in Room 221, County Office Building, Belmont, New York on the following items:

1. Culvert Pipe & Bands
2. Galvanized Corrugated Steel Beam Guide Rail, Posts, Block-Outs, and Back-Up Plates
3. Steel
4. Washed Crushed Gravel- Crushed Limestone
5. Highway Signs, Blanks and Posts
6. Bituminous Materials
7. 1311 Calcium Chloride
8. Crushed Gravel, Screened & Bank Run Gravel
9. Stone Fill (Rip Rap)
10. Ready Mix Concrete, Flowable Fill, and Concrete Blocks
11. Sand and Salt Mix
12. Rust Preventative Paint
13. Equipment Rental
14. Fiber Reinforced Bituminous Membrane Surface Treatment
15. Vegetation Control

Specifications for the above listed items may be obtained on the Internet: Allegany County Website at www.alleganyco.com; click on Public Works Department. They are also available at the Office of the Superintendent of Public Works, Room 210, County Office Building, Belmont, New York. It shall be the responsibility of each bidder to contact this office to determine if an addendum has been issued.

The Allegany County Department of Public Works reserves the right to reject any or all bids and to accept the bid it determines to be in the best interest of Allegany County.

Upon mutual agreement of the parties, Allegany County reserves the right to renew our contract (s) awarded as a result of this bid for an additional one (1) year period by resolution of the Public Works Committee of the Allegany County Board of Legislators in accordance with the specifications and NYS GML 103 and 104b.

David S. Roeske
Superintendent
Allegany County
Department of Public Works

DIRECTIONS FOR BID SUBMISSION

1. On envelope containing sealed bid:
 - a. Print your Company's name in upper left corner.
 - b. In lower left corner print:

Sealed Bid: March 16, 2010

Description of Item:

Item No:

***EACH BID SHOULD BE PLACED IN SEPARATE ENVELOPES**

2. Non-Collusive Bidding Certification shall accompany each bid.
3. The Allegany County Department of Public Works will receive sealed bids until 10:00 a.m. March 16, 2010. At that time bids will be opened in Room 221, County Office Building, Belmont, New York.
4. Specifications may be obtained on the Internet: Allegany County Website at www.alleganyco.com; click on Public Works Department. They are also available at the Office of Superintendent of Public Works, Room 210, County Office Building, Belmont, New York.
5. To be considered formal, bids must be submitted on enclosed bid submission sheets and be typewritten or written in ink. Any changes made should be initialed by an authorized party.
6. All bids shall remain open for 45 days after bid opening, unless hereinafter modified.
7. **To expedite the bid opening process, please submit ten (10) extra copies of your bid pages for distribution to other bidders.**

These copies should not be attached to your bid package.

INFORMATION FOR BIDDERS

All bids to be received by Allegany County Department of Public Works by 10:00 a.m., March 16, 2010. At that time bids will be opened in Room 221, County Office Building, Belmont, New York. The Allegany County Department of Public Works reserves the right to reject any or all bids and to accept the bid it determines to be in the best interest of Allegany County. All bid prices submitted shall be effective from date of bid award through May 1st, 2011.

It is understood and agreed that any Town, Village, School District or Fire District within Allegany County may also participate in this contract pursuant to Section 103, General Municipal Law. If the contract bidder sells a certain quantity of the bid items at a price below the Allegany County contract price to a political subdivision of Allegany County, the price to Allegany County must be reduced to the lower amount.

All bidders agree to defend and save Allegany County from and against all demands, claims, suits, costs, expenses, damages and adjustments based on any infringement of any patent relating to goods and materials specified in this bid.

A non-collusive bidding certificate must accompany all bids. All bids must be submitted on County provided bid sheets. Failure to provide a non-collusive bidding certificate or to submit a bid on the County provided form shall be cause for the bid to be rejected.

The Allegany County Department of Public Works reserves the right to reject any or all bids and to accept the bid it determines to be in the best interest of Allegany County.

All invoices of orders received shall be sent to the following address:

Allegany County DPW
7 Court Street, Room 210
Belmont, NY 14813-1078

Under no circumstances shall an invoice be sent to the address of delivery unless that address is the same as above.

All orders and invoices shall document the billing address and the delivery address or project location, as the majority of orders shall be different.

ALL ORDERS AND INVOICES SHALL HAVE THE QUANTITIES DELIVERED IN CUBIC YARDS NOT IN CUBIC METERS.

INFORMATION FOR BIDDERS AND CONDITIONS AND REQUIREMENTS APPLICABLE TO ALL BIDS AND AWARDS.

By submitting a bid the bidder certifies and agree as follows:

1. that it will maintain normal business hours during the time in which the material bid will be needed by the County. Bidders agree that normal business hours shall mean 8:00 a.m. to 4:00 p.m. Bidders also acknowledge and agree that on some occasions it may be necessary to remain open before or beyond normal business hours in order to provide the County with the material bid.
2. that all materials proposed or materials supplied by the bidder to the county shall conform to the requirements set forth in Standard Specifications, Construction and Materials manual published by the New York State Department of Transportation, Office of Engineering, January 2, 1990 (English measurement not metric) or to any other standard or standards for such materials or sources of materials specifically set fourth in these specifications. If the materials bid or the source of the materials bid are subject to certification or approval by the New York State Department of Transportation for materials or sources of materials which are purchased by the State of New York, the bidder certifies that the materials bid or proposed and/or the source of such materials are currently approved and/or certified by the State of New York Department of Transportation for use by the State of New York and the bidder shall furnish with his bid proof of such current approval or certification.
3. that the Superintendent of Public Works may order tests of the materials proposed by a bidder or supplied by a successful bidder, at any time, and that the costs of such testing shall be the responsibility of the bidder and/or successful bidder as the case may be. That the bidder and/or the successful bidder agrees to pay the costs of any such tests when presented with an invoice by the Superintendent of Public Works or by the testing entity.

**ALLEGANY COUNTY DEPARTMENT OF PUBLIC WORKS
BID SPECIFICATIONS FOR CEMENT CONCRETE, FLOW-ABLE FILL,
AND CONCRETE BLOCKS
March 16, 2010**

It is the intent of these specifications to describe the requirements for concrete, flow-able fill, and concrete blocks to be used by the Allegany County Department of Public Works for the period of bid award date, 2010 through May 1, 2011.

CONCRETE:

All concrete furnished shall meet the material requirements as specified in Section 501 of the New York State Department of Transportation or as modified by the Allegany County Department of Public Works.

Table 501-3 lists the following concrete mixtures:

Concrete Class: A Primary Use: General purpose structural

Concrete Class: D Primary Use: Thin structural applications

Concrete Class: E Primary Use: Structural slabs & approaches

Concrete Class: F Primary Use: High early strength

*Concrete with Fiber additive shall consist of 1.5# fiber per cubic yard of concrete.

Price bid per cubic yard will be delivered to any point within the four-quadrant breakdown of Allegany County. (See enclosed map).

A small load shall be defined as an original order placed with the bidder for less than three (3.0) cubic yards. Orders placed for greater than or equal to 3.0 cubic yards are not small loads. Trucks carrying less than 3.0 cubic yards as part of an initial order greater than or equal to 3.0 cubic yards are not small loads.

The bidder quotes the indicated prices for Controlled Low-Strength Material (CLSM), and Controlled Density Fill (CDF), delivered and placed subject to the following conditions and specifications:

A) DESCRIPTION:

CLSM is a flow-able, cementitious, self-compacting, self-leveling backfill material consisting of a mixture of portland cement, water, aggregate and/or fly ash. CDF is similar in performance and content, with the exception that an aggregate is not present. The work shall consist of furnishing and placing said material at various locations throughout the County, as directed by the County Superintendent, and in accordance with this Specification. The CLM backfill material shall have a

28-day compressive strength of between 40 psi and 200 psi, and shall conform to the specifications for "TYPE A", "TYPE B" or "TYPE C". CDF material shall conform to the specification for CDF.

B) MATERIALS:

The materials used for CLSM and CDF shall meet the following requirements:

- 1) Portland Cement, Type I or Type II, ASTM C-150.
- 2) Water
- 3) Fly Ash (if used), shall be tested for toxicity pursuant to a testing protocol approved by New York State Department of Environmental Conservation (NYS DEC) and certified to be non-toxic. The County shall be provided with a copy of documentation issued by NYSDEC attesting to its conformance with applicable NYS DEC rules and regulations. Fly ash shall conform to the chemical and physical requirements for mineral mixture, Class F listed in ASTM C618, including Table 2 (except for Footnote A). The loss on ignition shall be waived.
- 4) Aggregate (if used) shall have a 100% passing the 3/4" sieve.
- 5) Chemical Admixtures (if used) shall be a liquid or in a powdered form that is used in standard ready-mixed concrete production, unless specifically designed for a CLSM, i.e. high air generators.

C) MIXING & PLACING

- 1) Prior to mixing any CLSM or CDF backfill material, the Contractor shall submit to the County Superintendent results of laboratory tests, or results of tests made previously on CLSM or CDF used for other work. Test results shall show source and type, or class, of materials, batch proportions and conformance to the strength requirement.
- 2) All equipment for this work shall be subject to approval of the County Superintendent at all times. No work will be permitted until all equipment and the processing facilities are established, inspected and approved. The plant shall be either a continuous or a batch-type plant, designed to accurately proportion either by volume or by weight, such that a uniform mix will result.
- 3) Prior to placement, the operator shall insure a thorough and uniform mix, by mixing at the plant or in transit.
- 4) If prepared at a continuous plant, the mix may be transported in open-top haul units when the material is placed within 30 minutes of the end of mixing. Material placed in excess of 30 minutes after the end of mixing shall be transported in a rotating drum unit capable of 2-6 rpm.
- 5) Samples shall be cast in accordance with Materials Method 9.2 to verify that compressive strengths are within the specified limits. The frequency of test specimens will be determined by the County Superintendent.
- 6) The CLSM and CDF shall be accepted on the basis of inspection and approval by the Superintendent, and the method of placing CLSM and CDF shall be approved by the same.

D) MIX TYPES TO BE BID

The following three (3) CLSM mix types, and CDF mix, shall be used as a basis for this bid. Mix designs may be adjusted for a particular application, upon the approval of the County

Superintendent. It is not necessary to adhere to exact proportions as shown on page three (i.e. more fly ash and less sand may be acceptable), but mix design shall first be approved by the Superintendent.

CLSM

TYPE "A" MIX

(Not likely to be removed)

MIX DESIGN

100 lbs/yd Cement
300 lbs/yd fly ash
2750 lbs/yd aggre.
550 lbs/yd water

PROPERTIES

10-12 inch slump
flow-ability 35 ft.
400-800 PSI @ 28 da.

TYPE "B" MIX

(24-hr. strength, but removable)

MIX DESIGN

50 lbs/yd cement
400 lbs/yd fly ash
3000 lbs/yd aggre.
350 lbs/yd water

PROPERTIES

9-10 1/2 inch slump
Flow-ability 25 ft.
100-150 PSI @ 28 da.

TYPE "C" MIX

(6-hr. strength, but removable)

MIX DESIGN

50 lbs/yd cement
500 lbs/yd fly ash
2850 lbs/yd aggre.
275 lbs/yd water

PROPERTIES

8-9 inch slump
Flow-ability 20 ft.
100-200 PSI @ 28 da.

CDF MIX
(removable)

MIX DESIGN

75 lbs/yd cement
2300 lbs/yd fly ash
85 gals/yd water

PROPERTIES

6-12 inch slump
flow-ability 25ft.
50-150 PSI @ 28 da.

CONCRETE BLOCK SPECIFICATIONS

1. 3000 PSI 28 Day Comprehensive Strength Concrete
2. Reinforcement - #3 Rebar @ 8" O.C. Horizontal
3. Blocks shall have male/female interlock, 3" deep/tall – Reference Attached Drawing
4. Blocks shall be 24" wide
5. Blocks shall be available in 48", 60", 72", and 96" Lengths
6. All edges will have a 3/4" chamfer
7. Delivery must be available within five (5) working days
8. Blocks must be available with no minimum order
9. Block weights should be

4' = 1800 lb.	5' = 2250 lb.
6' = 2700 lb.	8' = 3600 lb.
10. Blocks will have recessed handles for setting
11. Supplier's catalog cut of block being bid shall be submitted with the bid
12. Concrete blocks with a similar design will be accepted upon approval of the Superintendent of Public Works.
13. No cold joints within the block shall be permitted.

Bidder shall assume that an initial order of 30 blocks shall be placed for pickup or delivery by June 1st (15 2'x2'x5' and 15 2'x2'x6')

Towns Within The
Northeast Quadrant

Allen
Almond
Angelica
Birdsall
Burns
Granger
Grove
West Almond

Towns Within The
Northwest Quadrant

Belfast
Caneadea
Centerville
Hume
New Hudson
Rushford

Towns Within The
Southeast Quadrant

Alfred
Alma
Amity
Andover
Independence
Scio
Ward
Wellsville
Willing

Towns Within The
Southwest Quadrant

Bolivar
Clarksville
Cuba
Friendship
Genesee
Wirt

All materials must be in compliance with and adhere to New York State Standard Specifications. Bidder must be listed on the current New York State Department of Transportation Materials Approved List for sources of fine and coarse aggregate. A copy of certificate of approval issued by the New York State Department of Transportation Materials Bureau, including Source number and Test number, indicating approval of material and inclusion on such List MUST accompany each bid.

**ALLEGANY COUNTY DEPARTMENT OF PUBLIC WORKS
BID PROPOSAL FOR CEMENT CONCRETE, FLOWABLE FILL, AND CONCRETE BLOCKS
March 16, 2010**

CONCRETE DELIVERED PRICE PER YARD:

Northeast Quadrant:

Concrete Class A: \$ _____
Concrete Class D: \$ _____
Concrete Class E: \$ _____
Concrete Class F: \$ _____

Southeast Quadrant:

Concrete Class A: \$ _____
Concrete Class D: \$ _____
Concrete Class E: \$ _____
Concrete Class F: \$ _____

Northwest Quadrant:

Concrete Class A: \$ _____
Concrete Class D: \$ _____
Concrete Class E: \$ _____
Concrete Class F: \$ _____

Southwest Quadrant:

Concrete Class A: \$ _____
Concrete Class D: \$ _____
Concrete Class E: \$ _____
Concrete Class F: \$ _____

FIBER MESH ADDITIVE CONCRETE DELIVERED PRICE PER YARD

Northeast Quadrant:

Concrete Class A: \$ _____
Concrete Class D: \$ _____
Concrete Class E: \$ _____
Concrete Class F: \$ _____

Southeast Quadrant:

Concrete Class A: \$ _____
Concrete Class D: \$ _____
Concrete Class E: \$ _____
Concrete Class F: \$ _____

Northwest Quadrant:

Concrete Class A: \$ _____
Concrete Class D: \$ _____
Concrete Class E: \$ _____
Concrete Class F: \$ _____

Southwest Quadrant:

Concrete Class A: \$ _____
Concrete Class D: \$ _____
Concrete Class E: \$ _____
Concrete Class F: \$ _____

\$ _____/load Small Load Charge
\$ _____/yard Heated Load Charge

Specify months where heated load charges apply: _____

**ALLEGANY COUNTY DEPARTMENT OF PUBLIC WORKS
 BID PROPOSAL FOR CEMENT CONCRETE, FLOW-ABLE FILL, AND CONCRETE BLOCKS
 March 16, 2010**

FLOWABLE FILL DELIVERED PRICE PER YARD:

Northeast Quadrant:

CLSM TYPE "A" \$ _____
 CLSM TYPE "B" \$ _____
 CLSM TYPE "C" \$ _____
 Controlled Density Fill \$ _____

Southeast Quadrant:

CLSM TYPE "A" \$ _____
 LSM TYPE "B" \$ _____
 CLSM TYPE "C" \$ _____
 Controlled Density Fill \$ _____

Northwest Quadrant:

CLSM TYPE "A" \$ _____
 CLSM TYPE "B" \$ _____
 CLSM TYPE "C" \$ _____
 Controlled Density Fill \$ _____

Southwest Quadrant:

CLSM TYPE "A" \$ _____
 CLSM TYPE "B" \$ _____
 CLSM TYPE "C" \$ _____
 Controlled Density Fill \$ _____

\$ _____/load SMALL LOAD CHARGE
 \$ _____/yd HEATED LOAD CHARGE

SPECIFY MONTHS WHERE HEATED LOAD CHARGES APPLY: _____

CONCRETE BLOCKS- PLANT

H W L	INTERLOCKING PRICE PER UNIT	NON-INTERLOCKING PRICE PER UNIT
24" x 24" x 48"	\$ _____ Each	\$ _____ Each
24" x 24" x 60"	\$ _____ Each	\$ _____ Each
24" x 24" x 72"	\$ _____ Each	\$ _____ Each
24" x 24" x 96"	\$ _____ Each	\$ _____ Each

CONCRETE BLOCKS- DELIVERED TO COUNTY HIGHWAY GARAGE LOCATED IN FRIENDSHIP

H	W	L	INTERLOCKING PRICE PER UNIT	NON-INTERLOCKING PRICE PER UNIT
24"	24"	48"	\$_____ Each	\$_____ Each
24"	24"	60"	\$_____ Each	\$_____ Each
24"	24"	72"	\$_____ Each	\$_____ Each
24"	24"	96"	\$_____ Each	\$_____ Each

Date: _____

Name of Firm: _____

Signature of Representative: _____
(Submitting the Bid)

Title of Representative: _____

Address of Firm: _____

Telephone Number: _____ Fax Number: _____

Tax Identification Number: _____

All bids to be received by Allegany County Department of Public Works by 10:00 a.m., March 16, 2010. Bids will be opened at that time in Room 221, County Office Building, Belmont, New York.

The Allegany County Department of Public Works reserves the right to reject any or all bids and to accept the bid it determines to be in the best interest of Allegany County.

RETAINING WALL BLOCK DETAIL

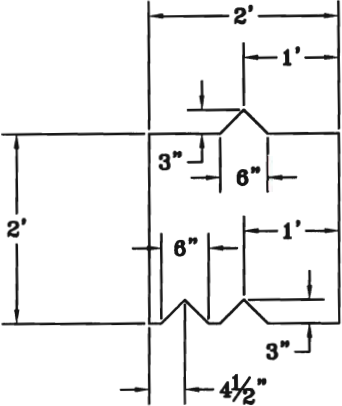

WITH INTERLOCK

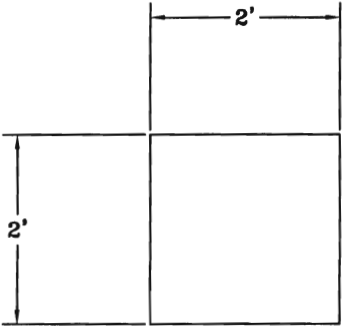

WITHOUT INTERLOCK

(Note - Lifting Loops Must Be Recessed - Not Shown)

ALLEGANY COUNTY DEPARTMENT OF
PUBLIC WORKS

7 Court Street, Room 210
Belmont, New York 14813
Telephone: 585-268-9230 Fax: 585-268-9648

NON-COLLUSIVE BIDDING CERTIFICATION

By submission of this bid, each bidder and each person on behalf of any bidders certifies, and in the case of a joint bid, each party thereto as to its own organization. Under penalty of perjury, that to the best knowledge and belief:

1. The prices in this bid have arrived independently without collusion, consultation, communication, or agreement, for the purpose of restricting competition, as to any manner relating to such prices with any other bidder or with any competitor;
2. Unless otherwise required by law, the prices which have been quoted in this bid have not been knowingly disclosed by the bidder and will not be knowingly be disclosed by the bidder prior to the opening, directly or indirectly, to any other bidder or to any competitor, and;
3. No attempt has been made or will be made by the bidder to induce any other person, partnership or corporation to submit or not to submit a bid for the purpose of restricting competition.

Name of Bidder

Signature of Bidder

Date

Subscribed and sworn to before me
This _____ day of _____, 20__

NOTARY PUBLIC

NOTE: If bidder is a corporation, the corporate name and title of officer Signing must be stated.